

PLEASE WAIT

Design by FAYE TOOGOOD

SPADE

CHAIR

to be

SEATED



PLEASE WAIT

We didn't choose this just so we could say, "We dig this chair." No more puns, promise (even though its designer's name is Toogood). The SPADE Chair harks back to the English rural tradition and an agricultural economy interleaved with everyday life. With a background in art industry, the British-born Faye Toogood rejects the sentimental view of the countryside in favour of a celebration of hard-wearing functionality.

This hardy chair suggests the handle of a spade as well as the classic, three-legged milking stool. It's a working piece. You can pile your towels on it in the bathroom, or unlace your muddy boots in the hallway. The shallow concave of the oval sit surface can be a stained Navy Blue, or left in its original, natural ash colour.

An ode to the English countryside. Or perhaps an elegy?

MATERIALS:

Solid ash wood

COLOURS:

Natural ash

Blue black

MEASUREMENTS:

Height: 86 cm

Seat height: 45 cm

Width: 44 cm

Depth: 48 cm

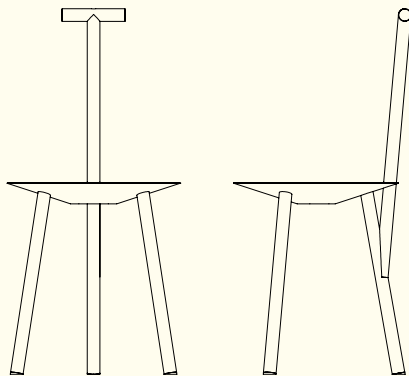

FAYE TOOGOOD (UK) has an eye for the raw, natural and irregular. Her trademark, numbered 'Assemblages' steer away from the formulaic and clichéd, opening up a space for exploring fresh materials and processes. Faye was born in the UK in 1977 and graduated with a BA in the History of Art in 1998 from Bristol University. She founded "Studio Toogood" in 2008 and "Faye Toogood" in 2010, both in London.



PLEASE WAIT to be SEATED A/S

Showroom

Frederiksgade 1, 1. floor
DK-1265 Copenhagen K
Denmark

+45 3155 2600

sales@pleasewaittobeseated.dk
pleasewaittobeseated.dk

SEATED