

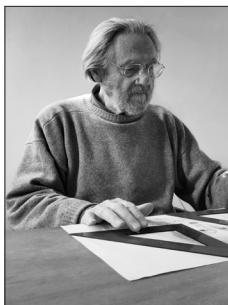

Scarpa 925

Design Afra & Tobia Scarpa

Year 1966



Afra & Tobia Scarpa

Afra Bianchin (1937-2011) and Tobia Scarpa (1935-) first met at the IUAV, University of Venice, where they graduated as architects in 1957. This marked the beginning of a partnership, marriage, and a career with an impressive impact on Italian design in the 1970s and 1980s. The Scarpa's influenced the golden years of design and production 'Made in Italy' with their modernist aesthetic and constant focus on the technical and aesthetic possibilities of materials in their designs. Their work consists of architecture, everyday household items, art glass, and exclusive home interior design pieces.



The iconic 925 Scarpa lounge chair is a strikingly elegant lounge chair. Easily recognized by its firm and robust wooden frame and the striking contrast it creates to the lightness of the leather covered seat and backrest.

The anatomical design of the leather-covered seat, combined with the natural elasticity of the cantilevered backrest, creates a lounge chair that is equally comfortable and strikingly elegant.

The 925 Scarpa lounge chair was designed alongside the charming 121 Scarpa dining chair from 1965. The two chairs are a prime example of Afra and Tobia Scarpa's work and share the same double trestle structure with characteristic rounded joints. Both designs are now a part of the Karakter collection.

PRODUCT DATA

Design	Afra & Tobia Scarpa. 1966
Product type	Lounge chair
Environment	Indoor
Materials	Frame in solid ash, upholstery in saddle leather, plastic glides

DELIVERY - LAUNCHES SEPTEMBER 2023

Lead time	16 to 18 weeks
-----------	----------------

CAL.117 & CMHR

CAL.117 and CMHR foam available

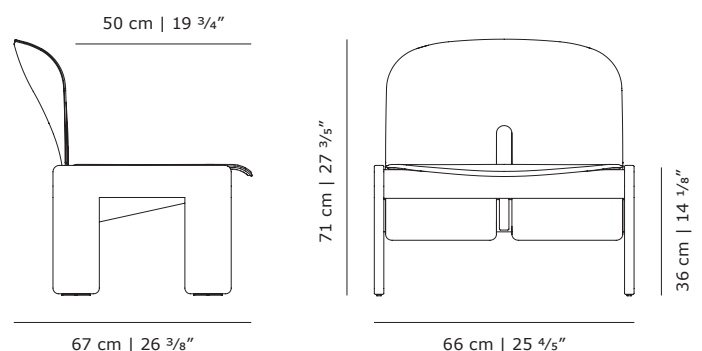



Scarpa 925

Frames and upholstery

Frames

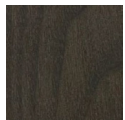

Solid ash
mocca stained

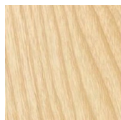

Solid ash
natural

Upholstery - Cassina saddle leather

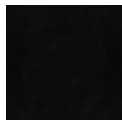

Nero



Rosso Bulgaro

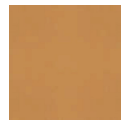

Naturale



Marrone



Cognac



Founded on rebellious curiosity and a passion for the unique, Karakter is a bit out of the ordinary. Rooted in the proud Danish design tradition, but always maintaining an international outlook, Karakter presents a striking portfolio of furniture, lighting and objects from designers who have already written the history of design to those who are aspiring to write the future. All designers collaborating with Karakter are curated for their ideas and creativity and shared by all of them is an inspiring level of curiosity and an uncompromising take on their work. Boasting both the relevant and honest, the beautiful, the playful and the expressive, all designs have a clear, undeniable character. Ready to spark curiosity and start conversations.

Head Office

Karakter
Gammel Lundtoftevej 1C
2800 Kongens Lyngby
Denmark

T +45 38 41 41 31
@karaktercopenhagen
info@karakter-copenhagen.com

Showroom - Paris

Karakter
242 Bis bd st Germain
75007 Paris
France

T +33 01 43 25 48 05
karakterparis@cassina.com

Karakter Corner - Milan

Cassina Showroom
Via Durini, 16
20122 Milano
Italy

T +39 02 76 02 07 45

