



Principal bar chair

Design Bodil Kjær

Year 1961



Bodil Kjær

She has been featured in The New York Times and Wall Street Journal Magazine. She designed a desk for MIT which was dubbed 'The most beautiful desk in the world' and eventually immortalized in three early James Bond movies. Danish architect, designer and professor Bodil Kjær (born 1932) is the female trail-blazer of Danish midcentury design, who although tutored by modernist master Finn Juhl, in her own words "... never had much interest in following in the footsteps of the Danish rat pack". Kjær looked to America, inspired by Charles and Ray Eames, and indeed many of her most notable designs stems from her time in the U.S., where she briefly worked at Paul McCobb, before moving to Boston to further her career in corporate interior architecture.



Drawing inspiration from Bodil Kjær's Principal chair from 1961, the Principal chair maintains the same functional and minimalistic design. Characterised by a simple and honest use of form and material, the design is timeless in every aspect.

It is meticulously designed down to the finest detail, offering an enduring piece to be cherished for generations. Balancing a geometric structure with soft organic shapes, the piece presents a simple structure that forgoes superfluous detailing in favour of a minimal design.

This ensures that the Principal bar chair can seamlessly adapt to various spaces, maintaining its relevance year after year.

PRODUCT

Design	Bodil Kjær. 1961
Product type	Bar chair
Environment	Indoor
Materials	Frame in solid oak or walnut with clear lacquer, footrest in anodized aluminium, HR foam on seat and backrest, upholstered with leather or textile, plastic or felt glides

DELIVERY - LAUNCHES OCTOBER 2024

Lead time	8 to 10 weeks
-----------	---------------

CRIB5

All textiles and leathers stated on this page comply with BS 5852, part 1 (cigarette & match proof)

Upholstery marked with (*) comply with BS 5852 CRIB5

CAL.117

All textiles and leathers stated on this page comply with US Cal. Bull. 117-2013, except Clay and Moss marked with (**)

3rd party leathers/textiles can be applied on request (subject to approval by Karakter). Please contact your Karakter sales representative for further information.

For COM/COL pricing, please refer to price group 1 for leather and textile respectively.

TEXTILE YARDAGE

Roll width	130 cm	140 cm	150 cm
@ 1 pcs.	1,05 m	1,05 m	1,05 m
@ 2 pcs.	1,70 m	1,45 m	1,45 m

LEATHER CONSUMPTION

An average of 1,25 square meters, depending on hide quality and individual hide shape.

Finishes

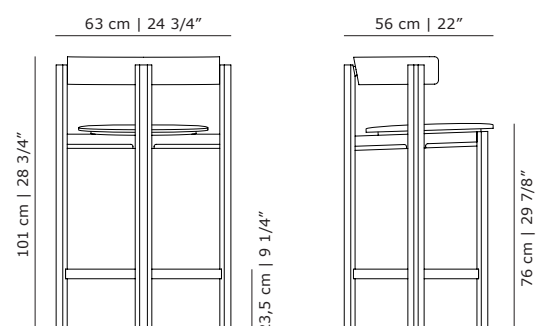



Founded on rebellious curiosity and a passion for the unique, Karakter is a bit out of the ordinary. Always maintaining an international outlook, Karakter presents a striking portfolio of furniture, lighting and objects from designers who have already written the history of design to those who are aspiring to write the future. All designers collaborating with Karakter are curated for their ideas and creativity and shared by all of them is an inspiring level of curiosity and an uncompromising take on their work. Boasting both the relevant and honest, the beautiful, the playful and the expressive, all designs have a clear, undeniable character. Ready to spark curiosity and start conversations.

Head Office

Karakter
Gammel Lundtoftevej 1C
2800 Kongens Lyngby
Denmark

T +45 38 41 41 31
@karaktercopenhagen
info@karakter-copenhagen.com